



# Knight 2RK30 Housing

USES TWO P2 SIZE BAGS

## FEATURES:

- LARGE AREA, HEAVY-DUTY BASKETS
- DUAL STAGE STRAINING OR FILTERING
- 304 STAINLESS OR 316 STAINLESS STEEL
- LIQUID DISPLACERS FOR EASIER SERVICING.
- ADJUSTABLE-HEIGHT TRIPOD LEGS
- SPECIAL OPTIONS AVAILABLE:  
INCLUDING SANITARY CONSTRUCTION,  
HIGHER PRESSURE RATINGS, EXTRA-LENGTH LEGS,  
AND HEAT JACKETING.
- FOR FLOW RATES TO 200 GPM
- LOW PRESSURE DROPS
- ELECTROPOLISHED
- ASME CODE STAMP AVAILABLE
- PERMANENTLY PIPED HOUSINGS

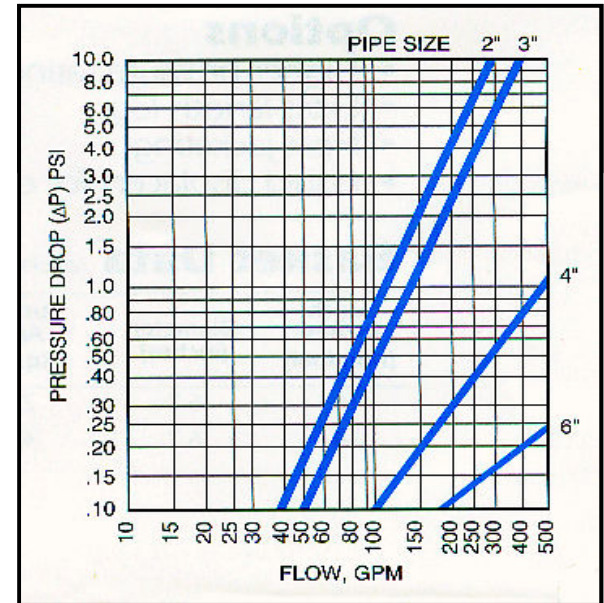
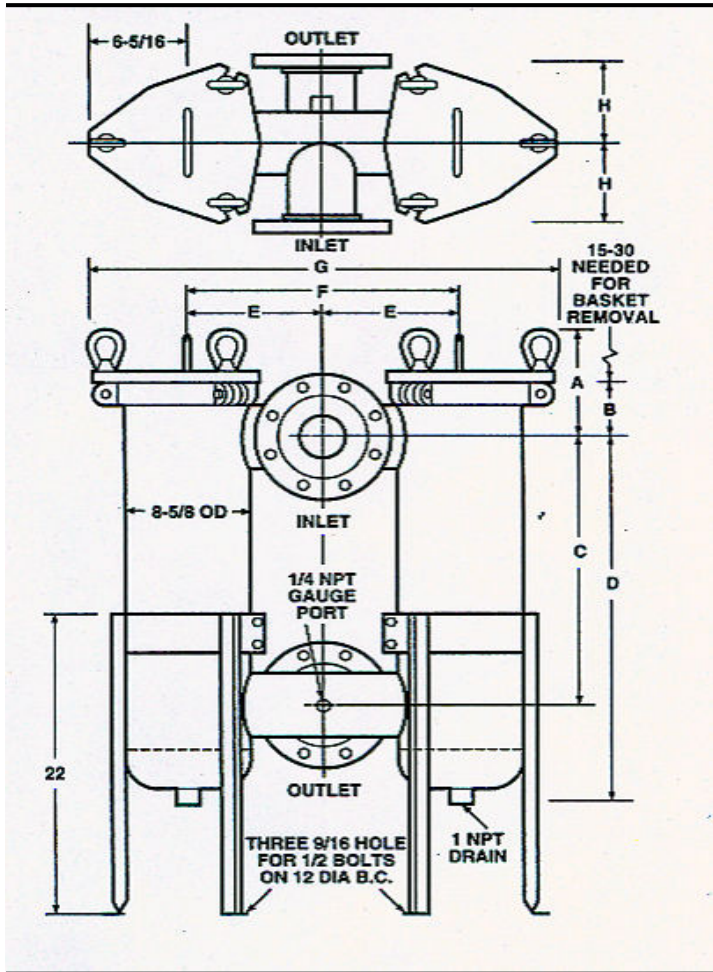

*\*Based on housing only. Fluid viscosity, filter bag used, and expected dirt loading should be considered when sizing a filter.*

## 2RK30 DIMENSIONS (INCHES, APPROXIMATE)

PIPE SIZE	A	B	C	D	E	F	G	H
2"	6.63	2.88	29.50	36.19	8.00	16.00	28.56	4.50
3"	7.50	3.75	29.50	37.09	8.00	16.00	28.56	5.50
4"	7.50	3.75	29.50	37.09	9.00	18.00	30.56	6.50
6"	9.00	5.25	29.50	38.56	9.00	18.00	30.56	8.00